

**PRODUCT SPECIFICATIONS**

**Construction:**

- Round Surface Mount
- Durable Die-Cast Aluminum
- Emergency Lithium Battery Backup Module Option
- Indicator LED Light And Test Button (EMG Option Only)
- Empty Casing Option To Be Used To Maintain Consistent Appearance With Fixtures Utilizing Battery Backup

**Light Source:**

- 90 Minutes Operation From Battery
- 24 Hour Recharge Time
- Emergency Operates At 60% Lumens
- 540 Lumens For The SL-LED9070R-WH-J And SL-LED1074-WH-J
- 630 Lumens For The SL-LED2074-WH-J

**Notes:**

- Installation Safety Wire For Effortless Install.
- Installs To Any 3" Or 4" Junction Box
- ETL Listed
- To Be Used For SL-LED9070R-WH-J Or SL-LED2074-WH-J OR SL-LED1074-WH-J

JOB NAME:	
TYPE:	



**Diameter: 8"**  
**Height: 1"**

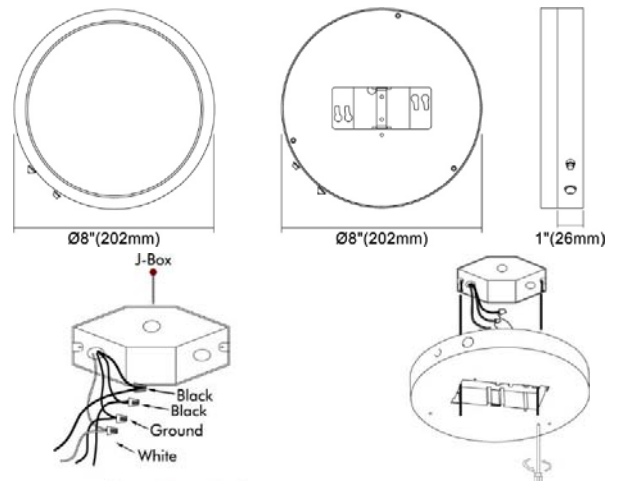

**Ordering Information**

Example: SL-LED9070R-EMG-WH

<b>SL-LED9070R</b>		<b>8"</b>	<b>WH</b>
SERIES	OPTIONS	DIAMETER	FINISH
SL-LED9070R	EMG-Battery Backup SHELL-Empty Casing	8"	WH-White

425 North Fox Street San Fernando, CA 91340  
(818) 365-8900 FAX (818) 365-2519  
www.southlandlighting.net

